

Full Length Research Paper

# Confirmatory factor analysis for testing validity and reliability of traditional knowledge scale to measure university students' attitudes

Ilker UGULU

Biology Department, Necatibey Faculty of Education, Balikesir University, 10100, Balikesir, Turkey.

Accepted 26 July, 2013

This study focuses on the confirmatory factor analysis for testing validity and reliability of Traditional Knowledge Attitude Scale (TKAS) to measure university students' attitudes. The items in the TKAS were developed initially from the responses to two open-ended items by 30 university students and literature review on traditional knowledge. This initial form was pilot tested with 396 university students from various departments and then subjected to exploratory factor analysis. Later, the revised version of the scale was administered to 469 university students, and those results were subjected to confirmatory factor analysis and reliability analysis. The TKAS consisted of three subscales and 15 items with responses recorded on a four-point Likert scale, options ranging from strongly agree to strongly disagree. Cronbach's alpha reliability coefficient ( $\alpha$ ) of the scale was found to be .90. Study results indicate that the TKAS can serve as a valuable tool for both instructors and researchers in Turkey to assess university students' traditional knowledge attitudes.

**Key words:** Traditional knowledge, attitudes, scale development, university students, environmental education.

## INTRODUCTION

Environmental education is a successive process that attempts to improve understanding of the environment and promote proenvironmental values, with the ultimate aim of motivating citizens to act individually and collectively in an environmentally conscious manner that balances the social, economic, and ecological needs of today without compromising those of the future (Farmer et al. 2007). In this regard, the definitive aim of environmental educators is to change individual behavior toward the environment by producing environmentally literate and responsible citizens (Knapp, 2000).

Environmental education obtained structural and goal-oriented qualities at global level in the care of IEPP within the scope of the Tbilisi Declaration. The Tbilisi Declaration constitutes the framework, principles and guidelines

for environmental education at all geographical levels from local to international as well as for all age groups regardless of whether such groups are subject to a formal school system (Wisconsin, 1994). The Tbilisi Declaration is considered a proclaimed fundamental document in the field of environmental education as well as provide a basis to carry it out in this field since 1978 (NAAEE, 1996). Besides, establishing overall goals for environmental education, the Tbilisi Declaration also ensured the following objectives regarding environmental education.

1. *Awareness* – to help social groups and individuals acquire an awareness and sensitivity to the total environment and its allied problems;
2. *Knowledge* – to help social groups and individuals gain

a variety of experiences in and acquire a basic understanding of, the environment and its associated problems;

3. *Attitudes* – to help social groups and individuals acquire a set of values and feelings of concern for the environment and motivation for actively participating in environmental improvement and protection;
4. *Skills* – to help social groups and individuals acquire the skills for identifying and solving environmental problems; and
5. *Participation* – to provide social groups and individuals with an opportunity to be actively involved at all levels in working toward resolution of environmental problems (UNESCO-UNEP, 1978).

To sum it up, the Tbilisi Declaration underlines that environmental education is not simply the presentation of information but it also provides learners with the opportunity to achieve environmental literacy consist of attitude and behavior components as well as knowledge component. Consequently, the objectives of environmental education is to provide learners with knowledge about the environment, to develop positive attitudes and behaviors towards the environment and to improve the skills of the citizens to take action effectively (Brownlee et al., 2013).

According to the Tbilisi Declaration, environmental knowledge is very important in terms of an effective environmental education. This case also shows the importance of traditional knowledge in the effective environmental education. Because, traditional knowledge is the information that people in a given community, based on experience and adaptation to a local culture and environment, have developed over time, and continue to develop (Hansen and VanFleet, 2003). This knowledge has been used for centuries by local communities under local customs and traditions (Ugulu and Aydin, 2011). For this reason, traditional knowledge has played a substantial role in vital areas such as food security, the development of agriculture and medical treatment (Correa, 2001).

Traditional knowledge includes intellectual inventories of local biological resources, animal breeds, and local plant species (Hansen and VanFleet, 2003). Furthermore, it includes practices and technologies on the use of biological and other materials for medical treatment and agriculture, production processes, designs, literature, music, rituals, and other techniques and arts (Mugabe, 1998). Traditional knowledge also encompasses belief systems that play a fundamental role in a people's livelihood, maintaining their health, and protecting and replenishing the environment. This knowledge is not static in nature and may include experimentation in the integration of new plant or tree species into existing farming systems or a traditional healer's tests of new plant medicines (Hansen and VanFleet, 2003). Therefore, it evolves and generates new information as a result of developments or adaptation to changing circumstances

(Correa, 2001).

In the light of these explanations, it is said that traditional knowledge is very important for social and cultural life and one of the main sources of many scientific and sociological researches. However, the continuation of this knowledge is endangered when transmission between the older and younger generation is no longer connected (Kargioglu et al. 2008). Whether the aims for a community include preserving, protecting, or sharing traditional knowledge, it is becoming increasingly important to record and document this knowledge. Education and especially environmental education assume a great responsibility at this stage.

Because students' attitudes must be changed to achieve this purpose. Student attitudes affect behavior of individuals, particularly the choice of action and persistence to make a decision. For example, students with high scientific literacy tend to make more appropriate decisions and seem more knowledgeable (Goodrum et al., 2001). From this point of view, it is important to examine student attitudes for the development, transmission and transformation of traditional knowledge.

As indicated in the objectives of the Tbilisi Declaration, the knowledge, attitudes and behaviors of the individuals towards the environment are considered as the main components in an efficient environmental education. Nevertheless, these components cannot be evaluated individually (Robelia et al., 2011). From this point of view, determining the correlation of knowledge, attitudes and behaviors together with their psychological and sociological aspects constitutes one of the basic problems of environmental education (Chao, 2012). This study is very important for referring to both the knowledge and the attitude dimensions. However, an extensive review of the literature on traditional knowledge researches indicated that there are no instruments that can provide valid and reliable data on students' attitudes toward traditional knowledge. For this reason, there is a lack of instrument on attitudes toward traditional knowledge which basically has lead to the emergence of this study. The present study reports on the development of an instrument to measure various constructs that explored important dimensions of students' attitudes toward traditional knowledge. The survey was conducted on a sample of university students.

## METHOD

### Sample

Three different samples were used to develop and validate Traditional Knowledge Attitude Scale (TKAS). Sample 1 was used for building an item pool, Sample 2 was used for pilot study and exploratory factor analysis (EFA) and Sample 3 was used for the main study; confirming the factor structure that was observed in exploratory factor analysis.

*The first sample* consisted of 30 university students (19 females, 11 males) from Balikesir and Dokuz Eylul Universities in Izmir and

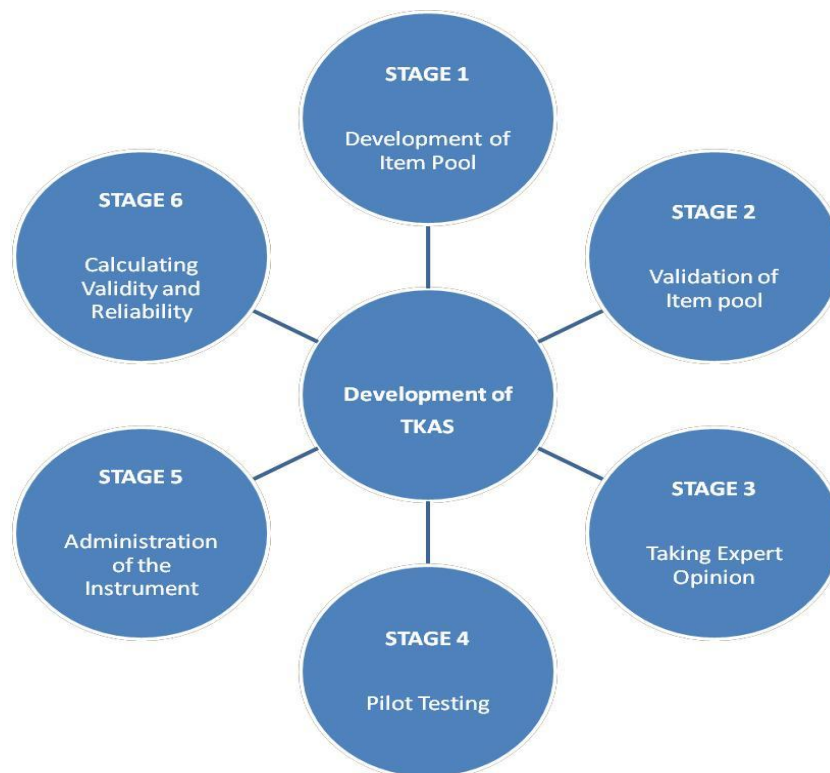

Figure 1. Development process of traditional knowledge attitude scale.

Balikesir Provinces. They were administered two open-ended items to get their responses in relation to traditional knowledge.

The second sample consisted of 396 students (221 females, 175 males) from 4 departments (Biology Education, Physics Education, Primary Mathematics Education, Science and Technology Education) in Balikesir and Dokuz Eylul Universities in Izmir and Balikesir. This sample was administered in the initial version of the TKAS built from the responses of the first sample. The responses gathered from Sample 2 were used for EFA.

The third sample, the main sample of the research, consisted of 439 (257 females, 182 males) from 4 departments (Biology Education, Physics Education, Primary Mathematics Education, Science and Technology Education) in Balikesir and Dokuz Eylul Universities in Izmir and Balikesir. The sample was administered in the revised version of the TKAS to validate and confirm the factor structure emerging from EFA. Confirmatory factor analysis (CFA) using AMOS.21 was employed to confirm the initial structure.

### Instrumentation

Traditional Knowledge Attitude Scale (TKAS) was developed in order to determine university students' attitudes toward traditional knowledge. Six-step model was used in order to develop the TKAS. These steps were illustrated in Figure 1. The specific actions which were taken for each step were presented below.

#### Step 1. Literature review and development of item pool

Before the development of item pool, an extensive literature review of traditional environmental/ecological/ethnobotanical knowledge

and environmental education was carefully searched and examined. In the perspective of the key characteristics of traditional knowledge, a total of 30 university students in Sample 1 were posed with the open-ended questions "What are your opinions on traditional environmental knowledge?" and "What are your opinions on traditional ethnobotanical knowledge?". Therefore, were asked to write an essay on the subject. Content analysis was used to analyze the data obtained from open-ended questions (Miles and Huberman, 1994; Yildirim and Simsek, 2005). The answers gave by the students to the questions were listed as a result in content analysis. In addition to these, a few items relating to traditional knowledge were reviewed from environmental attitude studies and instruments that were already developed and used in other studies (Correa, 2001; Ugulu and Aydin, 2011; Ugulu, 2011) to improve the intelligibility of the items and the content validity of the TKAS. Finally, the initial draft of the TKAS consisting of 38 items was constituted.

#### Step 2. Validation of item pool

Draft items were examined by two instructors and one curriculum development specialist for formal review. Each item was placed into matrix and then response were obtained to evaluate four areas: *content validity, clearness and understandability, accuracy and distracters*. After the literature search, the essential elements of the traditional knowledge as traditional medicine, plant and animal knowledge (Correa, 2001) and environmental knowledge and awareness (Ugulu and Aydin, 2011) were analyzed for evaluation of attitudes toward traditional knowledge and the pool of 38 items was reduced to 31. As a result of this external review, numerous items were revised.

### **Step 3. Taking expert opinion**

Regarding the items of TKAS, opinions and suggestions were sought from faculty members (n=11) and instructors (n=5) from the science education departments of Dokuz Eylul and Balikesir Universities. The experts were asked to examine items with regard to their relevance to purpose of the instrument, content coverage, understandability and consistency. In light of the expert opinions and suggestions, corrections were made and 2 new items were added. Validation of scope was sought in accordance with the expert suggestions. As a result, a scale of 33 items was produced to be used in pilot test.

### **Step 4. Pilot testing**

Traditional Knowledge Attitude Scale (TKAS), which was prepared according to expert opinions and suggestions, was applied to the Sample 2. This sample consisted of 396 students (221 females, 175 males) from 4 departments (Biology Education, Physics Education, Primary Mathematics Education, Science and Technology Education) in Balikesir and Dokuz Eylul Universities in Izmir and Balikesir, Turkey. The data-set obtained in this step was subjected to EFA, to check the factor structure of TKAS.

### **Step 5. Administration of the instrument to main sample**

Final draft of the instrument was administered to the Sample 3 of the research for calculating validity (particularly construct validity) and reliability of the instrument. The main sample, or the third sample, consisted of 439 (257 females, 182 males) from 4 departments (Biology Education, Physics Education, Primary Mathematics Education, Science and Technology Education) in Balikesir and Dokuz Eylul Universities in Izmir and Balikesir.

Students' responses were entered into an Excel file created for further analyses.

### **Step 6. Calculating validity and reliability**

The data collected from 439 university students were analyzed by means of factor structure and reliability analysis using SPSS (Statistical Package for the Social Sciences) version 21.0. A SPSS data-set was established based on the responses of these students on TKAS, and later converted to AMOS program for CFA. The purpose of this CFA was to compare these results to the factor structure/constructs emerging from the EFA in an attempt to validate the factor structure and TKAS. The factor structure observed in previous step was matched with the factor structure in this step.

## **RESULTS**

### **Factor structure of traditional knowledge attitude scale (TKAS)**

An exploratory factor analysis (EFA) was performed to examine the structure underlying the initial form of TKAS with 33 items. In order to determine the structure of the scale factor, varimax rotation method was used and principal components factor analysis method was applied to scores obtained from answers given by 396 students to the scale. The suitability of the data for factor analysis

can be tested by Kaiser-Mayer-Olkin (KMO) coefficient and Barlett Sphericity Test (Ugulu, 2011). KMO value was found to be 0.681 and acceptable in principal components factor analysis. Another indicator of the strength of the relationship among variables is Bartlett's test of sphericity. In this study, the observed significance level was  $p < 0.001$ . It is concluded that the strength of the relationship among variables was strong (George and Mallery, 2001).

EFA on the TKAS extracted 8 factors with eigenvalues exceeding 1.0. These factors altogether explained 76% of variance of results. Scree plot shows that three factors were in sharp descent and then started to level off. This was evidence that rotation was necessary for three factors. In general, three of eight factors were represented just by one item per each factor with loading higher than 0.4. Twelve items were deleted because their factor loadings were lower than 0.4 (Yavuz, 2005). In summary, twelve out of 29 attitude items were deleted and the factor analysis for rotation was run again over the data set with 17 items. Varimax rotation was used. Thus, the factor analysis resulted in three independent factors with factor loadings greater than 0.4. Table 1 presents factor loadings and factor structures of the items.

Three factors derived from the EFA accounted for 62.89% of total variance and these factors were named according to the common characteristics of the items loaded on the same factor. This total variance value is appropriate considering that other works focused on attitudes showed lower explained variance (Salta and Tzougraki, 2004: 47%; Spinner and Fraser, 2005: 42%). Eigenvalues of the factors are 6.588, 2.528 and 1.575, respectively. Table 2 gives the factors, eigenvalues and total variance explained. The proportion of explained variance by the prime factor in valid scales should be at least 20% (Reckase, 1979). Because our Factor 1 accounted for 38.725% of total variance (Table 2), these results are considered satisfactory. This suggests the presence of one major factor and thus reinforces the prior evidence concerning the internal consistency of the TKAS.

### **Description of TKAS Dimensions**

According to the data obtained from factor analysis, it was seen that items constituting TKAS were grouped under three subfactors. When items establishing subfactors were evaluated within themselves, it can be said that the first factor contains attitude items related to traditional medicine or ethnobotanical knowledge, while the second factor contains items related to plant and animal knowledge. And the third factor contains, in general, attitude items related to environmental knowledge and awareness.

The first factor included five items that focus on personal traditional medicine attitudes such as learning recipes of the herbal teas and phytopreparations,

**Table 1.** Factor structures and loadings of the 17 items in TKAS.

Items	F1	F2	F3
<b>Factor I (Attitudes toward traditional medicine knowledge)</b>			
TRAA1	0.882		
TRAA2	0.839		
TRAA3	0.802		
TRAA4	0.730		
TRAA5	0.595		
<b>Factor II (Attitudes toward plant and animal knowledge)</b>			
TRAB1		0.779	
TRAB2		0.731	
TRAB3		0.711	
TRAB4		0.696	
TRAB5		0.597	
TRAB6		0.564	
TRAB7		0.542	
<b>Factor III (Attitudes toward general environmental knowledge)</b>			
TRAC1			0.863
TRAC2			0.787
TRAC3			0.666
TRAC4			0.605
TRAC5			0.496

**Table 2.** Factor names, eigenvalues and variance of factors.

Factor names	Eigenvalues	Variance of factors
Attitudes toward traditional medicine knowledge (ATTMK)	6.588	38.755
Attitudes toward plant and animal knowledge (ATPAK)	2.528	14.871
Attitudes toward general environmental knowledge (ATGEK)	1.575	9.267

preparing and using phytoremedies. Thus, this factor was named as "Attitudes Toward Traditional Medicine Knowledge (ATTMK)". The mean score of the ATTMK dimension was 2.18 (SE = 0.04), which means that students showed negative attitudes toward traditional medicine and phytopreparations.

The second factor consisted of seven items which focus on items such as getting information about plants and animals in our environment and learning information about the benefits of plants and animals from elders. Since these items correspond to plant and animal knowledge, this dimension was named as "Attitudes Toward Plant and Animal Knowledge (ATPAK)". The mean score of the ATPAK dimension was 2.32 (SE = 0.04) which suggests that students are not aware of the important of the traditional knowledge about plants and animals.

The third factor consisted of five items such as talking

with people on environmental matters and making trips to natural areas. Because these items were concerned with the general notion of environmental knowledge and awareness, this dimension was called "Attitudes Toward General Environmental Knowledge (ATGEK)". The mean score of the ATGEK was the highest when compared with mean scores of other dimensions (M = 3.08, SE = 0.05), which means that students were relatively supportive some general environmental applications.

#### **Confirmatory factor analysis: Cross-validating initial factor structure**

Confirmatory factor analysis (CFA) was performed in data from sample 3 using the statistical package analysis of moment structures (AMOS.21) in order to confirm the factor structure that emerged in the EFA using data from

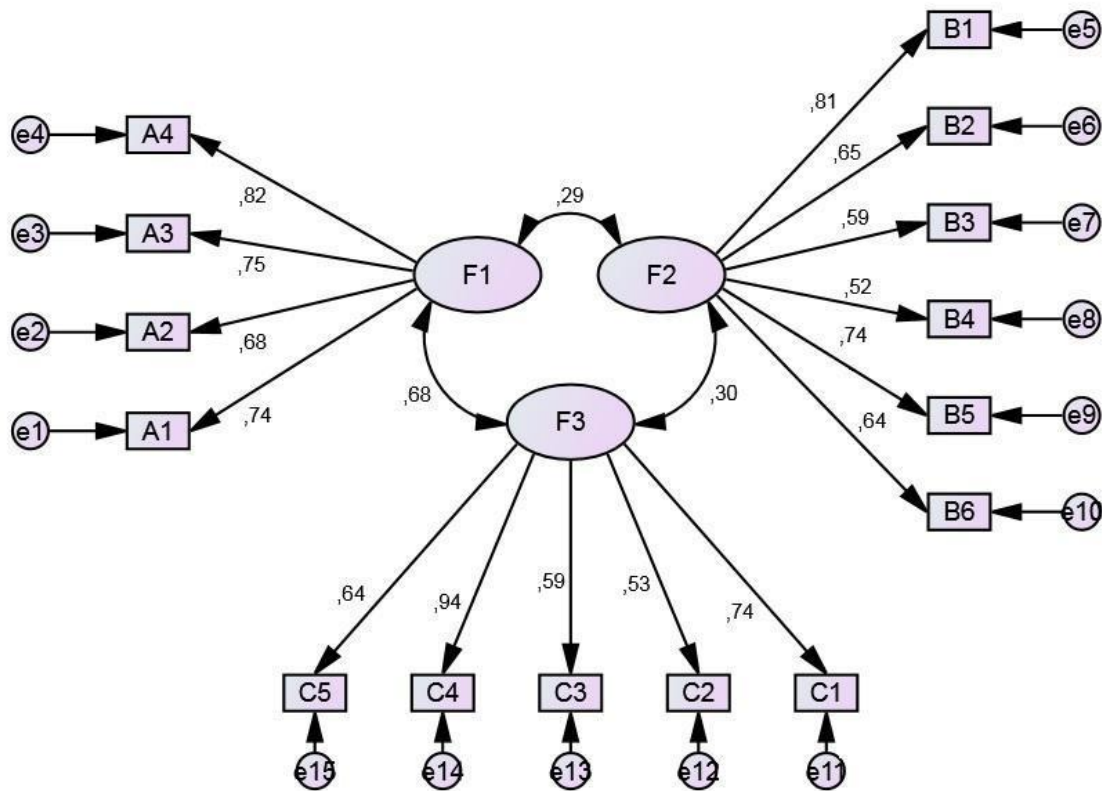

**Figure 2.** Standardized coefficients for the three-factors model for TKAS based on CFA through AMOS 21.0. All coefficients are significant at  $p < .001$ . NFI = .90, CFI = .91, RMSEA = .05; F1: Attitudes Toward Traditional Medicine Knowledge, F2: Attitudes Toward Plant and Animal Knowledge and F3: Attitudes Toward General Environmental Knowledge.

Sample 2 (Byrne, 2010). Various fit indices were used to test the adequacy of CFA models. The multiple goodness-of-fit tests/indexes used in CFA were: Normed Fit Index (NFI); Comparative Fit Index (CFI); and Root Mean Square Error Approximation (RMSEA). NFI is a normed fit index that has defined a tendency to consider fit index in large sample. NFI ranges between 0 and 1. CFI analyses the change in fit between the hypothesized model and the independence model (Byrne, 2010). The independence model compared with hypothesized model assumes that the variables in the model are unrelated. The CFI indicates the total co-variation in the model and ranges between 0 and 1. The values of NFI and CFI greater than .90 indicates a good fit to the data. RMSEA is based on the analysis of residuals (Kelloway, 1998). The expected value for a good model data fit is possible when RMSEA index value is below .08 (Kline, 2011). The value of RMSEA shows sensitivity to degree of freedom and complexity of the proposed model (Erdogan et al. 2012).

CFA using AMOS.21 was first undertaken to determine the fit between the hypothesized model with 17 items and the data. Three indexes of NFI, CFI, and RMSEA were

considered to assess this fitness. However, even if RMSEA index indicated acceptable fit value (RMSEA= .06), other measures in first CFA did not result in satisfactory fit indexes (NFI = .85, CFI = .87), indicating a questionable fit of the model to the data. This result pointed out the need for some modification in specification to find the best fitting model for the data from Sample 3. The output of CFA suggested regression paths (modification indexes) of two pairs of items (TRAA4–TRAA5 and TRAB2–TRAB6) were extensively high. The nature and the content of the items were assessed and observed to overlap in some degree, then one of the items in each pair was excluded (TRAA5 and TRAB6) from the second CFA.

After excluding the TKAS two items, CFA with 15 items were re-run to identify the model that represents the best fit to obtained data from Sample 3 (n = 439). This second CFA revealed that three factors emerged and confirmed the structure, which shows a good fit for data in Sample 3, with the fit indexes of NFI = .90 CFI = .91 and RMSEA= .05. All path coefficients were found significant at  $p < .01$  indicating a significant contribution of each item to the related factor. Thus, Figure 2 which illustrates,

**Table 3.** Reliability of each factor in the TKAS.

Factor names	Number of the item	Cronbach's alpha values
Attitudes toward traditional medicine knowledge	4	0.88
Attitudes toward plant and animal knowledge	6	0.88
Attitudes toward general environmental knowledge	5	0.77
Whole scale	15	0.90

three dimensions of TKAS were allowed to correlate to each other.

### Reliability coefficients of TKAS

In this study, for determining whether items of TKAS were consistent with each other or not, frequently used Cronbach alpha internal consistency coefficient was calculated. Considering results of the second CFA, reliability analysis for each factor was performed using SPSS 21.0 version. Each analysis revealed sufficient results.

Cronbach's alpha reliability coefficient ( $\alpha$ ) of first factor with six items "Attitudes Toward Traditional Medicine Knowledge (ATTMK)" was found to be .88, reliability ( $\alpha$ ) of second factor with six items "Attitudes Toward Plant and Animal Knowledge (ATPAK)" was found to be .88, reliability ( $\alpha$ ) of third factor with five items "Attitudes Toward General Environmental Knowledge (ATGEK)" was found to be .77, and reliability ( $\alpha$ ) of whole scale with fifteen items was found to be .90. Table 3 summarizes factor names, number of the items and reliability of each factor. Additionally, item total correlation score of all items in each reliability analysis yielded satisfactory results, which are higher than .30 (Field, 2005; Erdogan et al. 2012).

### Final version of TKAS

The final version of TKAS both in Turkish and in English were represented in Table 4. The Turkish version of the scale was translated into English in cooperation with a translator who is highly fluent in both English and Turkish.

## DISCUSSION AND IMPLICATIONS

In this study, confirmatory factor analysis of the TKAS was performed to assess university student attitudes toward traditional knowledge. The instrument was developed as a result of six-step instrument development processes: (1) an extensive literature review of research on environmental education and traditional environmental/ecological/ethnobotanical knowledge, and development of items pool with 30 university students (Sample 1); (2) validation of items pool; (3) taking opinions of experts on

various fields to improve content and face validity; (4) a pilot study with 396 students (Sample 2) to reveal initial factor structure; (5) administration of the final draft of the instrument to Sample 3 consisted of 469 students to establish data set; and (6) a cross-validation study to confirm the three-factor model and to ensure reliability evidences. This instrument (Traditional Knowledge Attitude Scale - TKAS) consisted of three dimensions and 15 items with responses recorded on a four-point Likert scale, options ranging from strongly agree to strongly disagree (4-Strongly agree, 1-Strongly disagree). The maximum score that can be obtained from the instrument is 60 and the minimum score is 15.

The construct validity of the TKAS was examined using factor analysis with varimax rotation. The results of the factor analysis revealed the three scales structure of the instrument which assessed Attitudes Toward Traditional Medicine Knowledge (ATTMK), Attitudes Toward Plant and Animal Knowledge (ATPAK), and Attitudes Toward General Environmental Knowledge (ATGEK). It was decided to exclude any item that does not have a factor loading of 0.40 or greater on its priori scale and less than 0.40 on all other environment scales. In the literature, 0.30 or higher is suggested for items loadings (Lang et al. 2005; Martin-Dunlop and Fraser, 2007). However, in the present study, a more conservative cut off score ( $\leq 0.40$ ) was selected in order to differentiate among the scales of the instrument in this preliminary development of the scale. It may seem that about half of the variability is unaccounted for, however 62.89% explained variability is considered as sufficient variance explanation in social sciences studies (Tabachnick and Fidell, 2001). Overall, these results support the factorial validity of the TKAS.

The Confirmatory Factor Analysis (CFA) showed that all path coefficients were high and significant at  $p < .05$ , representing a meaningful contribution of each item to the corresponding scale. Having conducted two confirmatory factor analyses, the three factor model was found to show a good fit with acceptable fit indexes (NFI = .90, CFI = .91, and RMSEA = .05). CFA provide an evidence for the construct validity of TKAS with the sample of university students. Thus, at the end of the six steps, the TKAS was found to consist of three factors underlying 15 items, all of which were measured on a four-point Likert-type scale. The first factor, Attitudes Toward Traditional Medicine Knowledge (ATTMK), consisted of four items that focus on personal traditional medicine attitudes such

**Table 4.** English and Turkish Version of Traditional Knowledge Attitude Scale.

<b>Traditional Knowledge Attitude Scale (Geleneksel Bilgiye Yönelik Tutum Ölçeği)</b>	<b>Strongly Agree (Kesinlikle katılıyorum)</b>	<b>Agree (Katılıyorum)</b>
<b>Attitudes Toward Traditional Medicine Knowledge</b>		
(Geleneksel İlaç Bilgisine Yönelik Tutumlar)		
(TRAA1) 1. I think herbal teas and phytopreparations prepared at home help to drugs.	( )	( )
(TRAA1) 1. Evde hazırlanan bitki çayları ve bitkisel karışımlar ilaçlara yardımcıdır.		
(TRAA2) 2. I think home-made herbal teas and phytopreparations are beneficial in terms of health.	( )	( )
(TRAA2) 2. Ev yapımı bitki çayları ve bitkisel karışımlar sağlık için yararlıdır.		
(TRAA3) 3. I would like to drink home-made herbal teas (linden, sage, mint-lemon, etc.) when I am sick.	( )	( )
(TRAA3) 3. Hastalandığımda ıhlamur, adaçayı ve nane-limon gibi ev yapımı bitki çaylarını içmek isterim.		
(TRAA4) 4. I can prepare some herbal teas myself.	( )	( )
(TRAA4) 4. Bazı bitki çaylarını kendim hazırlayabilirim.		
<b>Attitudes Toward Plant and Animal Knowledge</b>		
(Bitki ve Hayvan Bilgisine Yönelik Tutumlar)		
(TRAB1) 5. The knowledge of the elderly people is a major source in terms of the biodiversity in our region.	( )	( )
(TRAB1) 5. Yaşadığımız bölgedeki biyoçeşitlilik açısından yaşlı insanların bilgisi önemli bir kaynaktır.		
(TRAB2) 6. I enjoy getting information about plants and animals in our environment from my family and elders.	( )	( )
(TRAB2) 6. Çevremde yaşayan bitki ve hayvanlar hakkında büyüklerimden bilgi almaktan hoşlanırım.		
(TRAB3) 7. I am aware of the benefits of plants and animals to humans.	( )	( )
(TRAB3) 7. Bitki ve hayvanların insanlara olan faydalarının farkındayım.		
(TRAB4) 8. I am curious about the conditions and habitats of animals.	( )	( )
(TRAB4) 8. Hayvanların yaşama ortamları ve koşullarını merak ederim.		
(TRAB5) 9. I ask my family and elders which plants and animals live in our area.	( )	( )
(TRAB5) 9. Bölgemizde hangi bitki ve hayvanların yaşadığını büyüklerime sorarım.		
(TRAB6) 10. I would like to learn the growing conditions of various plant species.	( )	( )
(TRAB6) 10. Çeşitli bitkilerin yetişme koşullarını öğrenmeyi severim.		
<b>Attitudes Toward General Environmental Knowledge</b>		
(Genel Çevre Bilgisine Yönelik Tutumlar)		
(TRAC1) 11. I know environmentally important places (wetlands, national parks, etc.) in my surrounding areas.	( )	( )
(TRAC1) 11. Yaşadığım bölgenin çevre açısından önemli alanlarını (sulak alanlar, milli parklar vs.) bilirim.		
(TRAC2) 12. I talk with people around me on environmental matters such as endangered species.	( )	( )
(TRAC2) 12. Çevremdeki insanlarla tehlike altındaki canlı türleri gibi çevresel konular hakkında konuşurum.		
(TRAC3) 13. I am curious about how the natural events occur.	( )	( )



Table 4. Contd.

(TRAC3) 13. Doğa olayları nasıl oluşur merak ederim.		
(TRAC4) 14. I enjoy making trips to natural areas (prairie, forest, etc.) in my surrounding areas with my family and elders.	( )	( )
(TRAC4) 14. Büyüklerimle yaşadığımız bölgedeki doğal alanlara (kır, orman vs.) geziler ve yürüyüşler yapmaktan hoşlanırım.		
(TRAC5) 15. I would like to recognize the natural environment in my surrounding areas.	( )	( )
(TRAC5) 15. Yaşadığımız doğal çevreyi tanımayı çok isterim.		

as learning recipes of the herbal teas and phyto-preparations, preparing and using phyto-remedies. The second factor, Attitudes Toward Plant and Animal Knowledge (ATPAK), included six items which focus on items such as getting information about plants and animals in our environment and learning information about the benefits of plants and animals from elders. The third factor, Attitudes Toward General Environmental Knowledge (ATGEK), consisted of five items such as talking with people on environmental matters and making trips to natural areas.

Cronbach's alpha reliability coefficients for the three dimensions were also examined. Analyses revealed that all of the coefficients were high enough to be considered adequate, namely, all items lead to a higher alpha coefficient for the overall scale reliability. The results of reliability for the scales ranged from 0.77 to 0.88. The highest alpha coefficients were for ATTMK and ATPAK. Cronbach Alpha coefficient for the whole scale was determined as 0.90. Liu (2003) stated that limited value for scale reliability could be taken as 0.70. However, he also reported that reliability values of 0.60 for preliminary studies, 0.80 for basic studies and 0.90-0.95 for applied studies were necessary. As a result, it can be said that reliability coefficients of the scales exceed the value of 0.60, which is considered acceptable for

research purposes (Nunnally, 1967). The high values of the alpha coefficients suggest that the instrument displayed adequate internal consistency. These results showed that TKAS is internally consistent and reliable for interpreting traditional attitudes among university students.

One of the fundamental goals of institutions and agencies supporting science is integrating research and education because of the benefits to society of a more informed and scientifically literate population (Gould et al., 2010). In order for increasing individuals who are sensitive towards environment and traditions, first their level of knowledge, awareness and attitude toward environment should be determined and then it must be improved upon (Unal and Dimiski, 1999). Therefore, attitudes toward traditional knowledge of all university students should be measured and education practices must be put in place to change these attitudes for the better. In this context, valid and reliable scales have an important role to play in changing attitudes for the better, in terms of both time and cost.

Eventually, TKAS is a encouraging instructional tool for in especially environmental education, ecology and ethnobotany to explore students' attitudes towards traditional knowledge. Instructors can use the instrument for measuring attitudes and obtaining more specific views in three

dimensions. In a tool in applied q tors can use observing the ef on the attitudes that it would be other countries reliability of th attitudes of the ledge from a wi evaluation of th different grade groups of the pu

#### REFERENCES

- Brownlee MTJ, Pow foundational proc change: opportun Environ. Educ. Re Byrne BM (2010). Basic concepts, NY: Taylor & Fran Chao Y (2012). Pre theory of planne environmental be Correa C (2001). property: Issues traditional knowl Office (QUNO). Erdogan M, Ok A, validation of child

- scale. *Environ. Educ. Res.* 18 (4):507-540.
- Farmer J, Knapp D, Benton GM (2007). An elementary school environmental education field trip: Long-term effects on ecological and environmental knowledge and attitude development. *J. Environ. Educ.* 38(3):33-42.
- Field A (2005). *Discovering statistics using SPSS*. London: Sage.
- George D, Mallery P (2001). *SPSS for windows: step by step*. Allyn & Bacon, USA.
- Goodrum D, Hackling M, Rennie L (2001). The status and quality of teaching and learning of science in Australian schools. Research report. Training and Youth Affairs. <http://www.dest.gov.au/NR/>. Accessed 14 Oct 2008.
- Gould WA, Gonzalez G, Walker DA, Ping C (2010). Integrating research, education, and traditional knowledge in ecology: A case study of biocomplexity in arctic ecosystems. *Arctic Antarctic Alpine Res.* 42(4):379-384.
- Hansen S, VanFleet J (2003). Traditional knowledge and intellectual property: A handbook on issues and options for traditional knowledge holders in protecting their intellectual property and maintaining biological diversity. Washington, DC: American Association for the Advancement of Science (AAAS).
- Kargioglu M, Cenkci S, Serteser A, Evliyaoglu N, Konuk M, Kok MS, Bagci Y (2008). An ethnobotanical survey of Inner-West Anatolia, Turkey. *Hum. Ecol.* 36:763-777.
- Kelloway EK (1998). *Using LISREL for structural equation modeling: A researcher's guide*. Thousand Oaks, CA: Sage.
- Kline RB (2011). *Principles and practices of structural equation modeling*. New York, NY: The Guilford Press.
- Knapp D (2000). The Thessaloniki Declaration: A wake-up call for environmental education? *J. Environ. Educ.* 31(3):32-39.
- Lang QC, Wong AFL, Fraser BJ (2005). Student perceptions of chemistry laboratory environments, student-teacher interactions and attitudes in secondary school gifted education classes in Singapore. *Res. Sci. Educ.* 35:299-321.
- Liu Y (2003). Developing a scale to measure the interactivity of websites. *J. Advert. Res.* 6:207-217.
- Martin-Dunlop C, Fraser BJ (2007). Learning environment and attitudes associated with an innovative science course designed for prospective elementary teachers. *Int. J. Sci. Math. Educ.* 6:163-190.
- Miles MB, Huberman MA (1994). *An expanded sourcebook qualitative data analysis*. London: Sage.
- Mugabe J (1998). Biodiversity and sustainable development in Africa. – In: Mugabe, J. & Clark, N. (eds) *National systems of conservation and innovation in Africa*, Nairobi: African Centre for Technology Studies (ACTS).
- Nunnally J (1967). *Psychometric theory*. New York: McGraw Hill.
- Reckase MD (1979). Unifactor latent trait models applied to multifactor tests: results and implications. *J. Educ. Stat.* 4:207-230.
- Robelia BA, Greenhow C, Burton L (2011). Environmental learning in online social networks: adopting environmentally responsible behaviors. *Environ. Educ. Res.* 17(4):553-575.
- Salta K, Tzougraki C (2004). Attitudes toward chemistry among 11th grade students in high schools in Greece. *Sci. Educ.* 88:535-547.
- Spinner H, Fraser BJ (2005). Evaluation of an innovative mathematics program in terms of classroom environment, student attitudes, and conceptual development. *Int. J. Sci. Math. Educ.* 3:267-293.
- Tabachnick BC, Fidell LS (2001). *Using multivariate statistics*. Boston: Allyn & Bacon.
- Ugulu I (2011). The impact of recycling education on the knowledge, attitudes and behaviors of secondary school students. Ph.D. diss., Dokuz Eylul University, Turkey.
- Ugulu I, Aydin H (2011). Research on students' traditional knowledge about medicinal plants: Case study of high schools in Izmir, Turkey. *J. Appl. Pharmaceut. Sci.* 1(9):43-46.
- Unal S, Dimiski E (1999). UNESCO-UNEP himayesinde çevre eğitiminin gelişimi ve Türkiye'de ortaöğretim çevre eğitimi. *Hacettepe Üniversitesi Eğitim Fakültesi Dergisi* 17:1421-54.
- UNESCO-UNEP (1978). *Unesco-Unep environmental education newsletter*. *Connect* 3(1):1-8.
- Wisconsin Department of Public Instruction (1994). *A guide to curriculum planning in environmental education*. Wisconsin: Madison.
- Yavuz S (2005). Developing a technology attitude scale for preservice chemistry teachers. *Turk. Online J. Educ. Technol.* 4:1-9.
- Yıldırım A, Simsek H (2005). *Sosyal bilimlerde nitel araştırma yöntemleri*. Ankara: Seçkin Yayıncılık.